



# PMC-1302-3

## Ethernet Serial/LoRa Gateway



### Overview

The PMC-1302-3 ESG is an Industrial Ethernet Serial/LoRa Gateway which provides one 10/100BaseT Ethernet port, two RS-485 ports and an optional wireless LoRa port with configurable ISM Bands. It is an ideal equipment for connecting RS-485 and optionally LoRa enabled devices to an IP-based Ethernet LAN, making it possible to access RS-485 and LoRa enabled devices over an Ethernet network for any SCADA or Automation applications. It also provides multiple Masters support for both Modbus and Transparent Gateway functions. Further, the PMC-1302-3 ESG has been specifically designed with industrial automation in mind and therefore provides un-surpassed performance and reliability under the harshest industrial or commercial environments.

### Applications

The PMC-1302-3 ESG supports the efficient transfer of serial packets between the upstream network-based applications and the downstream RS-485 or optionally LoRa wireless devices via a TCP/IP connection. Instead of using a Windows based "Virtual COM" driver with a port-mapping utility, which is often plagued with driver incompatibility among many different Windows versions, the PMC-1302-3 allows applications to directly connect to it via a TCP/IP connection for the transparent transfer of serial packets inside TCP/IP frames to and from downstream devices. Perfectly suited for communicating with industrial devices that have timing sensitive protocols, the PMC-1302-3 ESG provides a reliable interface for SCADA or similar applications that already support direct connection with Ethernet Gateway to communicate with serial devices independent of the protocols used.

The PMC-1302-3 ESG also supports the Modbus TCP to Modbus RTU Gateway function that makes it extremely simple for any Modbus TCP Master applications to interface with Modbus RTU enabled IEDs over a local area network. A simple web-based interface allows users to easily configure the TCP to RTU address mapping for downstream Slave IEDs connected via RS-485 or optional LoRa.

The PMC-1302-3 ESG can be enabled to support multiple Masters to facilitate information sharing while minimizing the implementation cost. In addition, the optional LoRa port supports configurable ISM Bands for wireless IoT applications in most countries.

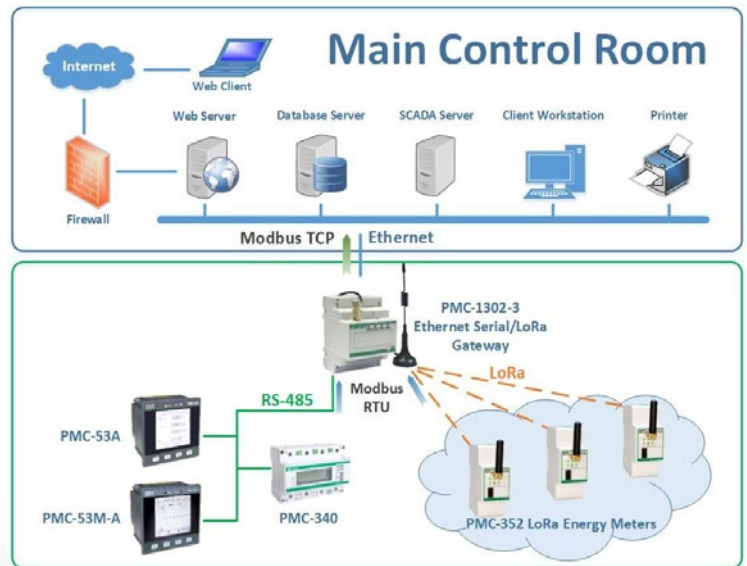

### Features

- 1x10/100BaseT (RJ45) and 2xRS-485 ports are designed to withstand the harshest industrial environments
  - 1.5kV isolation protection for the Ethernet port
  - 8kV (contactless) & 6kV (contact) ESD protection and 3kV isolation protection for all serial ports
- Optional LoRa port with configurable ISM Bands for EU863-870, RU864-870, IN865-867, US902-928, AU915-928, AS920-923 and AS923-925
- Transparent Gateway between Ethernet port and RS-485/LoRa
  - TCP Server/Client and UDP Server/Client modes
  - Maximum 4 Masters per RS-485/LoRa port
  - Maximum 128 downstream LoRa devices per PMC-1302-3
- Modbus TCP to RTU Gateway
  - TCP Server and TCP Client modes
  - 32 Slave IEDs per RS-485 port
  - Maximum 8 Modbus TCP Masters
- One-key Reset to Factory Default
- Simple configuration via its built-in web interface
- DIN Rail Mount
- Extended operating temperature

## Standard of Compliance

Safety Requirements	
Insulation	EN 61010-1: 2010 EN 61010-2-030: 2010
Dielectric Test	2kV @ 1 minute
Insulation Resistance	>100MΩ
Impulse Voltage	5kV, 1.2/50μs

## Electromagnetic Compatibility

CE EMC Directive 2014/30/EU (EN 61326: 2013)

Immunity Tests	
Electrostatic Discharge	EN 61000-4-2: 2009
Radiated Fields	EN 61000-4-3: 2006+A1: 2008+A2: 2010
Fast Transients	EN 61000-4-4: 2012
Surges	EN 61000-4-5: 2014+A1: 2017
Conducted Disturbances	EN 61000-4-6: 2014
Magnetic Fields	EN 61000-4-8: 2010
Voltage Dips and Interruptions	EN 61000-4-11: 2004+A1: 2017

Emission Tests	
Limits and Methods of Measurement of Electromagnetic Disturbance Characteristics of Industrial, Scientific and Medical (ISM) Radio-Frequency Equipment	EN 55011: 2016
Electromagnetic Compatibility of Multimedia Equipment-Emission Requirements	EN 55032: 2015
Limits for Harmonic Current Emissions for Equipment with Rated Current ≤16 A	EN 61000-3-2: 2014
Limitation Of Voltage Fluctuations And Flicker In Low-Voltage Supply Systems For Equipment With Rated Current ≤16 A	EN 61000-3-3: 2013
Emission Standard for Residential, Commercial and Light-Industrial Environments	EN 61000-6-4: 2007+A1: 2011

Mechanical Characteristics	
Spring Hammer Test	IEC 62052-11: 2003
Vibration Test	IEC 62052-11: 2003
Shock Test	IEC 62052-11: 2003

## Technical Specifications

Communication	
Ethernet Port (P1)	
Speed	10/100 Mbps
Protocol	TCP, UDP, HTTP
RS-485 (P2, P3)	
Baudrate	300/600/1200/2400/4800/9600/19200/38400 bps
Data Bits	7, 8
Stop Bits	1, 2
LoRa (Optional)	
RF Range	860-935 MHz
ISM Bands	EU863-870, RU864-870, IN865-867, US902-928, AU915-928, AS920-923 and AS923-925
RF Output Power	18 dBm (Maximum)
Receiver Sensitivity	-136 dBm (Maximum)
Output Watts	0.03 (Typical)
FCC Part 15C	Certified by TCB
Front Panel LED Indicators	
Run (Green)	Blinking - System is running normally
Data (Yellow)	Blinking - LoRa is receiving or transmitting data
P2, P3 (Green)	Blinking - Receiving activity
P2, P3 (Yellow)	Blinking - Transmitting activity

Power Supply (L/+, N/-)	
Standard	95-250VAC/DC, 47-440Hz
Optional	20-60VDC
Burden	≤ 3W
Protection	
ESD Protection	8kV (contactless) & 6kV (contact)
Isolation Protection	3kV for RS-485, 1.5kV for Ethernet Port
Environmental Conditions	
Operating Temp.	-25°C to +70°C
Storage Temp.	-40°C to +85°C
Humidity	5% to 95% non-condensing
Atmospheric pressure	70kPa to 110kPa
Mechanical Characteristics	
Unit Dimensions	72x65x95mm
Mounting	DIN Rail
IP Rating	20

## Ordering Information

Product Code		Description				
PMC-1302-3 Ethernet Serial/LoRa Gateway						
Basic Function	T		Supports Modbus Gateway and Transparent Gateway			
Power Supply	2		95-250VAC/DC, 47-440Hz			
	3		20-60VDC			
Wire Communication		T2	1x10/100BaseT, RJ45 Connector and 2xRS-485			
		N	None			
Wireless Communication		7*	LoRa (860-935 MHz) configurable for EU863-870, RU864-870, IN865-867, US902-928, AU915-928, AS920-923 and AS923-925			
Language		E	English			
PMC-1302-3	-	T	T2	N	E	PMC-1302-3-T2T2NE (Standard Model)

\* Additional charges apply

## Dimensions

Unit: mm

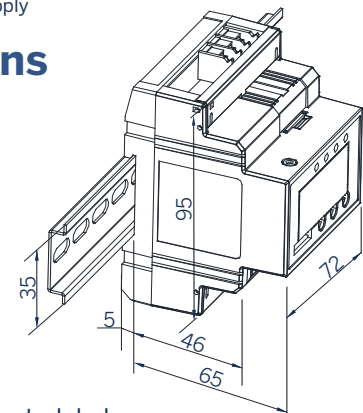

Email: [sales@cet-global.com](mailto:sales@cet-global.com)

Website: [www.cet-global.com](http://www.cet-global.com)

Copyright © CET Inc. All rights reserved.

Your Local Representative

V:00 12.12.2022